

INTEGRAL ELECTRONICS (IEPE) PIEZOELECTRIC ACCELEROMETER

MODEL 2010A

- Outstanding Dynamic Range
- Wide Bandwidth
- Low Impedance Output
- Side Connector
- Stud Mounted



actual size

Description

The VIP Sensors Model 2010A is a stud mounted piezoelectric accelerometer designed for general vibration measurement on structures and objects. It features a high signal-to-noise ratio, a high output sensitivity, and a wide bandwidth. The accelerometer transmits its low impedance voltage output through the same cable that supplies the constant current power.

The Model 2010A design is sealed against external contamination. Signal ground is connected to the outer case of the unit. When used with an isolated mounting stud, the accelerometer is electrically isolated from ground. The accelerometer features a 10-32 side connector that is used with coaxial cable for error-free operation.

VIP Sensors Signal Conditioner Models 5005, 5100 and 5102 are recommended for use with this low impedance accelerometer.

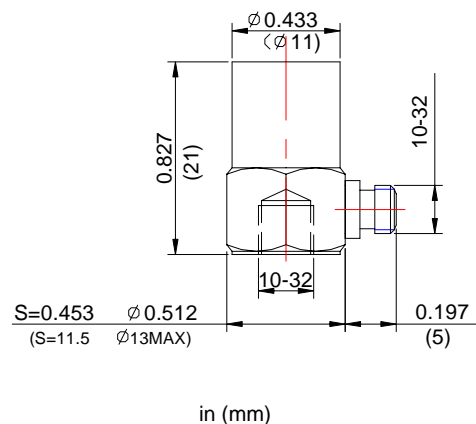

in (mm)

Typical Amplitude Response

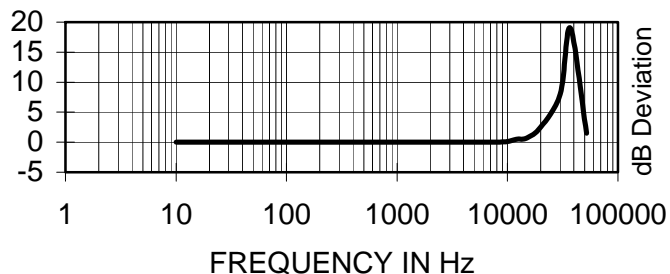

Typical Temperature Response

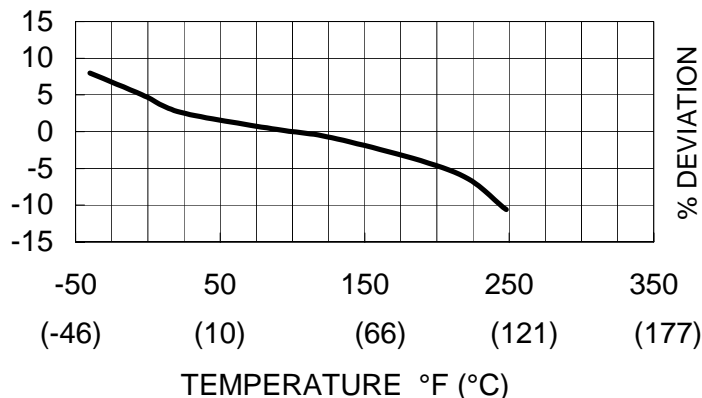

INTEGRAL ELECTRONICS (IEPE) PIEZOELECTRIC ACCELEROMETER

MODEL 2010A

SPECIFICATIONS

The following performance specifications conform to ISA-RP-37.2 (1964) and are typical values, referenced at +75°F (+24°C) and 100 Hz, unless otherwise noted. Calibration data, traceable to National Institute of Standards and Technology (NIST), is supplied.

	UNITS	
DYNAMIC CHARACTERISTICS		
Range	g (m/s ²)	500 (4903.3)
Voltage Sensitivity, typical	mV/g (mV/m/s ²)	10 (1.02)
Transverse Sensitivity	%	≤ 5
Frequency Response		See Typical Amplitude Response
Resonance Frequency	Hz	35,000
Amplitude Response		
± 5 %	Hz	1 – 8,000
± 1 dB	Hz	0.5 – 10,000
Temperature Response		See Typical Temperature Response
Amplitude Linearity	%	< 1
ELECTRICAL CHARACTERISTICS		
Output Polarity		Acceleration directed from base into the transducer defined as positive
Power Source Voltage (Constant Current)	VDC	+12 to +28
Supply Current	mA	2 to 10
Bias Voltage	V	7 ±1
Full Scale Output Voltage (peak)	Vp	≤ 5
Output Impedance	Ω	< 100
Noise	mg (mm/s ²)	< 5 (< 49.0)
Grounding		Signal ground connected to case
ENVIRONMENTAL CHARACTERISTICS		
Temperature Range		-4°F to 248°F (-20°C to +120°C)
Humidity		Epoxy sealed
Shock Limit	g pk (m/s ² pk)	1,000 (9807)
Base Strain	equiv. g /μstrain	0.0006
Magnetic Field Sensitivity	equiv. g rms /gauss (T)	1E-4 (10)
Thermal Transient Sensitivity	equiv. g /°C	0.12
PHYSICAL CHARACTERISTICS		
Weight	oz (grams)	0.5 (14)
Case Material		Stainless Steel
Mounting		10-32, torque 2 N-m (18 lbf-in)
Piezoelectric Material		PZT-5
Structure		Center Compression
Output Connector		10-32 receptacle, side mounting

ACCESSORIES

Included:

9005L10 Coaxial Cable 10-32/BNC, 10ft (3.3 m)
 9504-8 10-32/10-32 Mounting Stud
 Calibration Sheet

Optional:

9006L10 Coaxial Cable 10-32/10-32, 10 ft (3.3 m)
 9505-8 10-32/10-32 Isolated Mounting Stud

NOTES

- Short duration shock pulses, such as those generated by metal-to-metal impacts, may excite transducer resonance and cause linearity errors.