

Smart Piezoelectric Accelerometer

**MODEL
2300**

- Digital Output
- Programmable Full Scale:
± 1.2 g to ± 500 g
- Noise Floor: 7 mg rms
- Freq Response: 1 Hz to 2 KHz
- Programmable Digital Filter
64 Order FIR Type
Filter Corners: 10 Hz to 12 KHz
- A/D Converter
16-bit, Programmable Sample Rate
up to 250 Ksps
- IntelliBus Compliant



Size: 1.5 x 1.5 x 0.8 inches

Description

VIP Sensors' Model 2300 Smart Piezoelectric Accelerometer consists of a piezoelectric sensor stack, a semiconductor temperature sensor and all of the necessary front-end signal conditioning, data acquisition, data processing as well as the Intellibus-compliant digital bus. It is packaged in a small, low-profile metal case with two pig-tail connectors for daisy chaining the Intellibus-based network. Its low-noise front end signal conditioning and programmable gain allows for measurement of a wide range of vibration levels. Temperature readings from its built in sensor may be used for on- or off-board temperature correction.

There are two software selectable 3-pole anti-aliasing filters, one with a cut-off frequency at 2 KHz and another at 360 Hz. The 16-bit A/D converter samples data at a programmable rate up to 250 Ksps. A powerful processor performs digital signal processing algorithms such as digital filter, etc.

The Transducer Electronic Data Sheet stored in non-volatile memory provides the information needed to set up the highly versatile signal conditioner and data acquisition parameters.

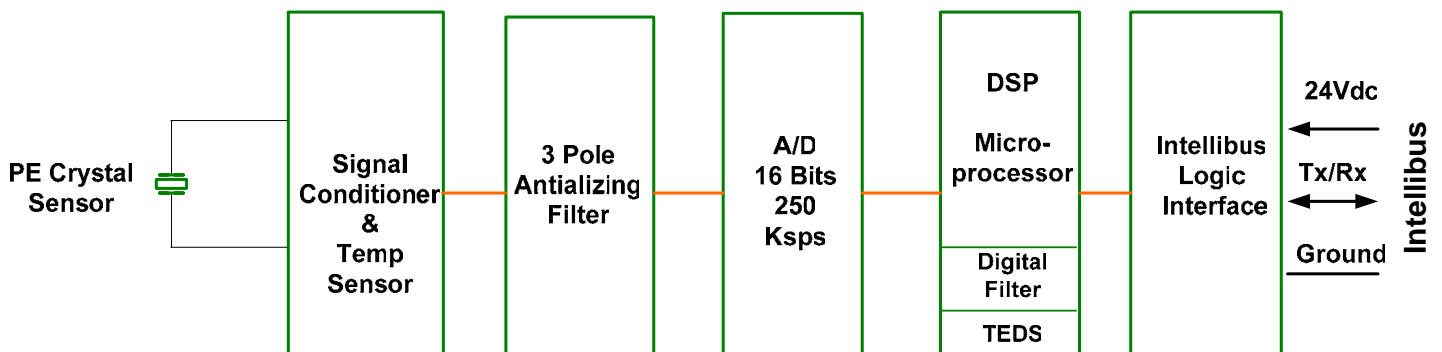

Smart Piezoelectric Accelerometer Functional Diagram

Smart Piezoelectric Accelerometer

MODEL 2300

SPECIFICATIONS

The following performance specifications conform to ISA-RP-37.2 (1964) and are typical values, referenced at +75°F (+24°C) and 100 Hz, unless otherwise noted. Calibration data, traceable to National Institute of Standards and Technology (NIST), is supplied.

PERFORMANCE	UNITS	
DYNAMIC CHARACTERISTICS		
Full Scale Input Range	g pk	± 1.2 to ± 500 programmable
Noise	%	0.3 of full scale max
Accuracy	%	±0.2 Electronic signal conditioner and Data Acquisition ±1.5 Sensor Calibration Uncertainty at 100 Hz
Sensitivity Temp Coefficient	Equiv g/°c	0.018
Transverse Sensitivity	%	< 1 typical
Amplitude Linearity	%	< 2
Bandwidth (F-5%)	Hz	1 to 20,000 No filter, accelerometer and signal conditioner only
Anti-aliasing Low Pass Filter	Hz	3 pole Butterworth
-3dB Upper Freq. Corner	Hz	2,000 or 360 Software selectable and factory customized
Programmable Digital Filter		64th Order FIR type – TEDS programmable coefficients
Cutoff Frequency		Programmable, proportional to sample rate , decimation factor and filter's coefficients – See application notes
ANALOG/DIGITAL CONVERSION		
Sample Rate	Ksps	Programmable up to 250
Resolution	bps	16
Transducer Bus		½ Duplex Intellibus compatible
Data Rate	Mbps	15Mbps. See sample rate Vs Number of IBIMs plot
	V	
	V	
POWER		
Supply Voltage		12 to 28 VDC 2.4 Watts Maximum
Warm-Up Time		3 seconds to within 10% of final basis
Case Isolation		Output and signal ground, 100 MΩ minimum @ 100 Vdc
ENVIRONMENTAL		
Operating Temperature	°F (°C)	-40 to +255 (-40 to +125)
Shock	g	6,000 (0.5 ms Half-sine period in each directional axis)
Vibration	g rms	2000 (20-2000 Hz random)
Humidity		Epoxy sealed
PHYSICAL		
Size	Inch (mm)	1.5L × 1.5W × 0.5D (38 x 38 x 13)
Weight		2 Oz.
Case Material		Anodized Aluminum
Cable Type		Double shielded 2 pairs, 24AWG: Tensolite NF24Q100-01
Intellibus Connector		Lemo: FGG-OB-304-CLAD42 and FGG-OB-304-CLLD42

Smart Piezoelectric Accelerometer

MODEL 2300

Typical Frequency Response of Accelerometer

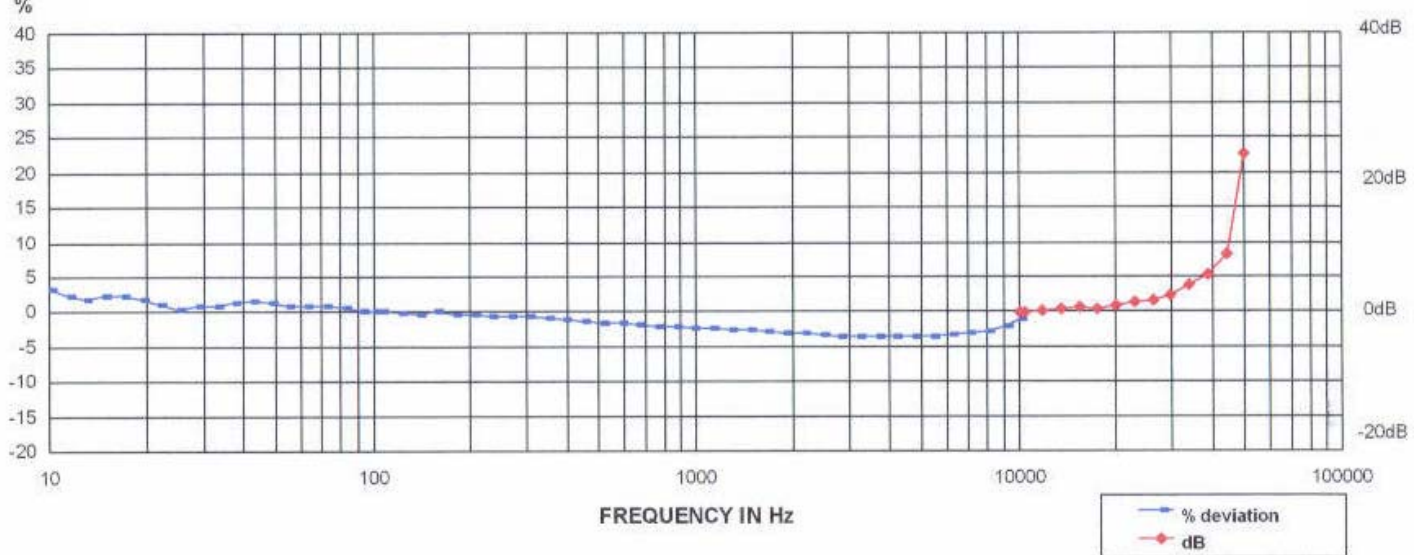

Digital Filter:

Different analysis and control functions may be implemented using DSP algorithms that can be downloaded to an IBIM through the transducer bus. A 64 order FIR filter is provided as a standard function. Its coefficients may be customized and downloaded through the IntelliBus network as part of the system setup and stored in TEDS memory. The low pass filter cutoff frequency (F_c) is determined by the A/D sample frequency and a preset constant

$$F_c = F_{ad}/R$$

Where $R = 4, 8, 12, 16, 24, 32$

The Sample rate frequency over the transducer bus (F_s) is determined by the A/D sample frequency and the decimation factor D

$$F_s = F_{ad}/D$$

Where $D \leq R/2$ Integer

One of the two anti-aliasing filters is selected depending on the over sample frequency according to the Nyquist criteria. The recommended over sample frequency should be between 100 kHz and 16 kHz when the 2 kHz anti-aliasing filter is used, or between 11,520 Hz and 2,880 Hz when the 360 Hz anti-aliasing filter is used.

Smart Piezoelectric Accelerometer

MODEL 2300

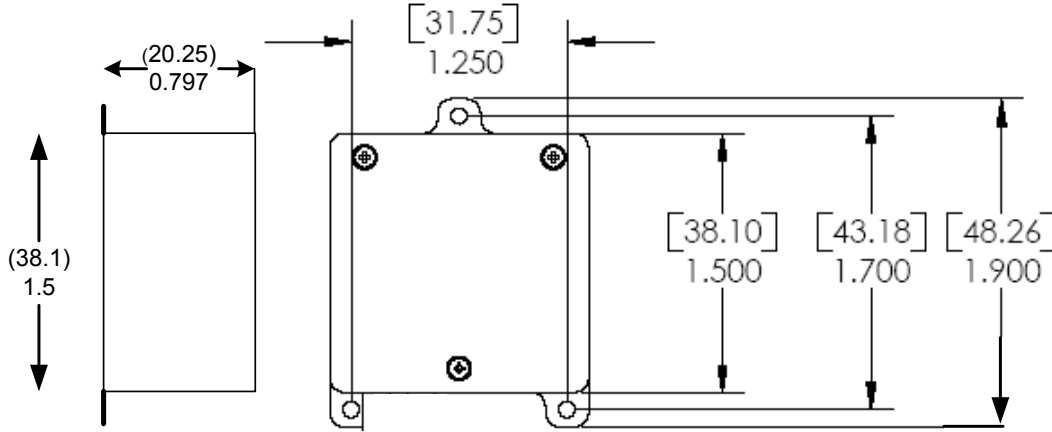

Sensor Outline Drawing

Bus Rate vs. Samples Per Second

Half-Duplex, No Interleave, Trigger and Poll, including Time of Flight

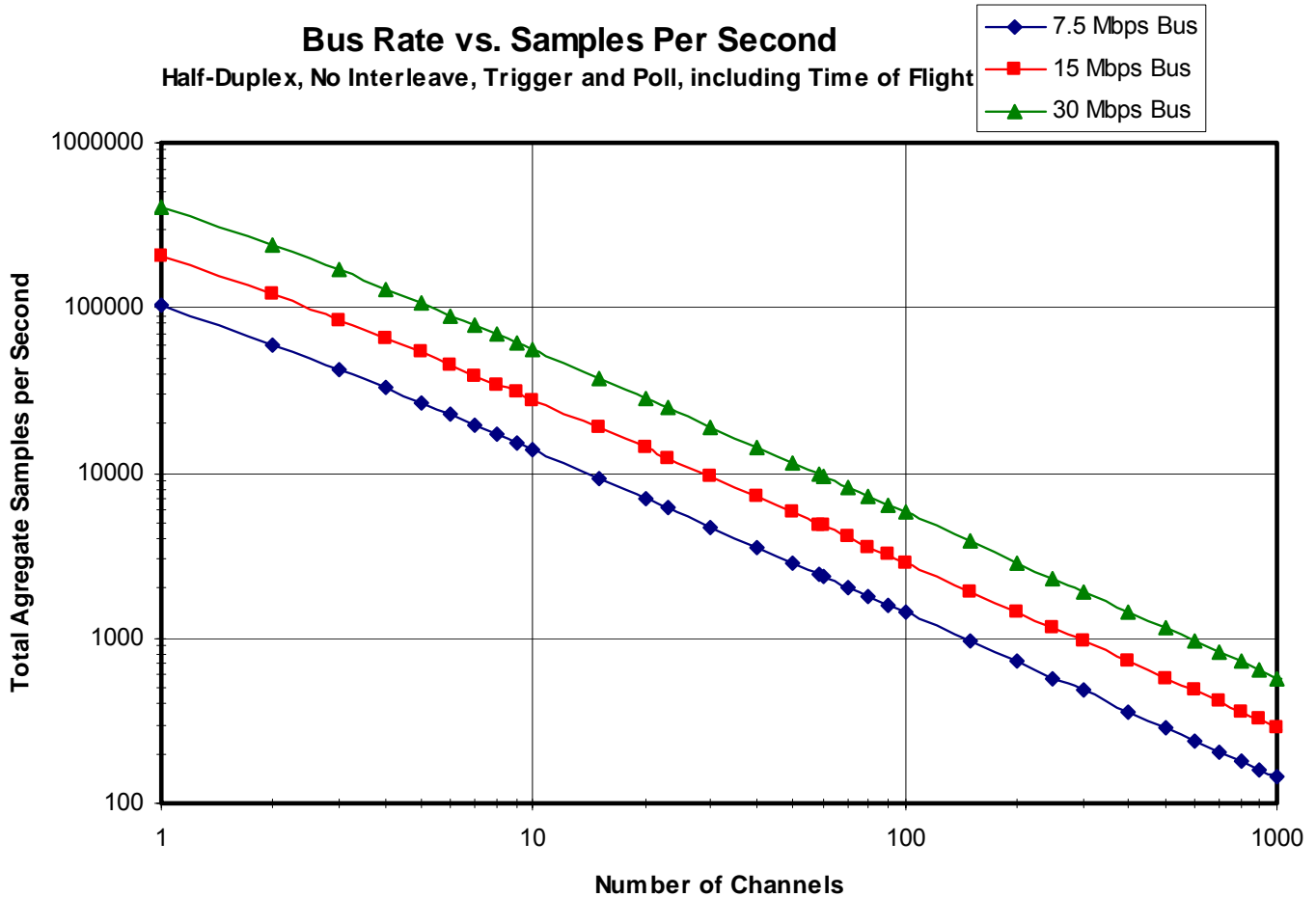

Figure 4: Bus Transfer Rate – Sample Rate Versus Number of IBIMs