

Three Channel Base Add-on Module

MODEL 6004

- 3 Differential or Single-Ended Voltage Inputs
- Programmable Gain and Offset
- Programmable Digital Filter
 - 64th Order FIR Type
 - Filter Corners: 10 Hz to 12 KHz
- A/D Converter
 - 16 Bits
 - Programmable Sample Rate up to 250 Ksps/ch, 300 Ksps Aggregate
- IntelliBus Network Interface



1.5" x 1.5" x 0.6"

Description

The VIP Sensors Model 6004 Add-on Module consists of 3 channels of differential input instrumentation amplifiers with programmable gain (0.5 to 1000) and a programmable offset that allows conditioning of bridge type transducers such as strain gages, accelerometers, thermocouples, etc. Each of the front-end signal conditioners is followed by two selectable 3-pole anti-aliasing filters, one with a cut-off frequency at 2 kHz and another at 360 Hz. There is one 16-bit A/D converter per channel with a programmable sample rate up to 250 Ksps max, but the aggregate rate for all three channels must be less than 300 KHz. Access to the IntelliBus transducer bus network is achieved through the stacked modules to the IntelliBus Base Module.

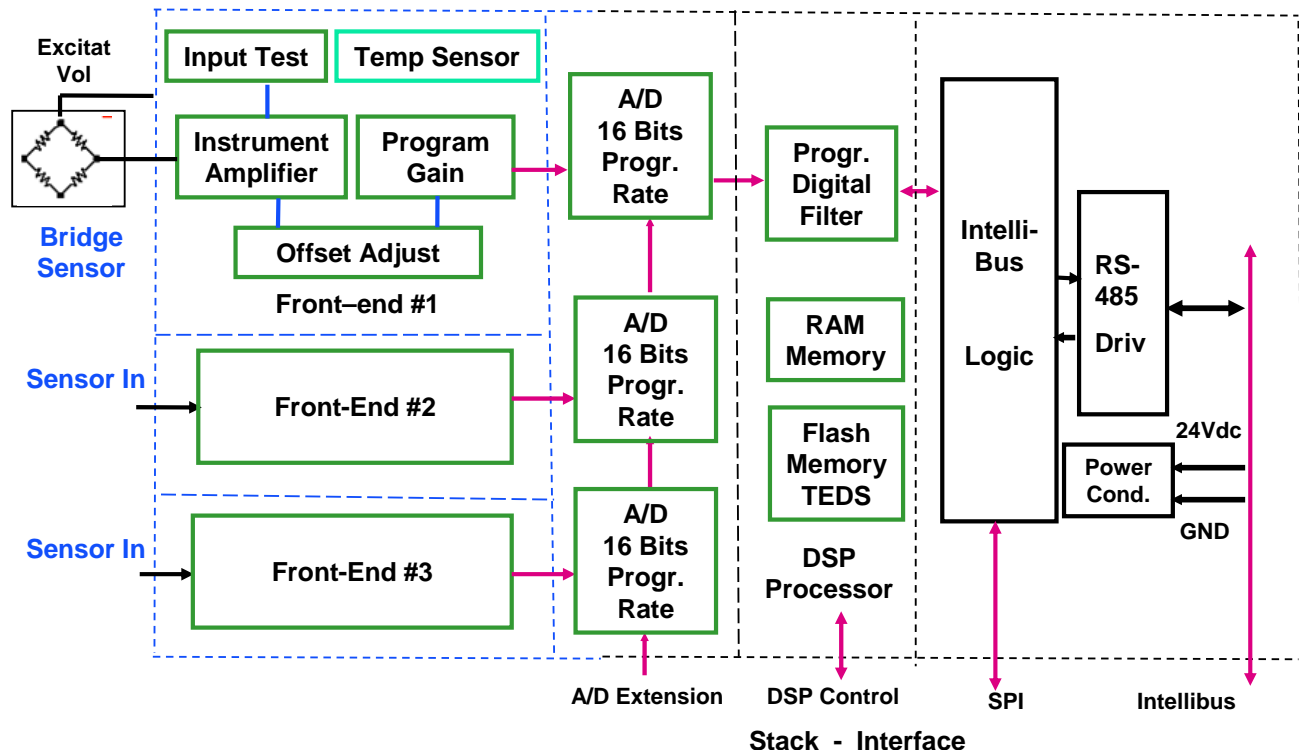

Three Channel Base Add-on Module

MODEL 6004

Description

Over-sampled data is acquired simultaneously in all three channels and piped into a powerful DSP processor capable of implementing real time digital signal processing algorithms. The processor also performs self-testing functions of its electronics.

Each of the IBIM Channels have dedicated non-volatile memory to store the Transducer Electronic Data Sheet (TEDS).

Filters (programmable filter types and corner frequencies, such as 6 pole low pass type) are easily implemented by choosing the proper filter coefficients and storing them as part of the TEDS through the transducer bus.



Base Add-on with Stack-Up Access

Multiple IBIM's are stacked to increase its channel count density per node. Interconnection within a stack is done through the SPI port, the DSP processor control lines or through IntelliBus without the need of additional bus connectors. A single Base Module or Base Add-on Modules support up to a thirty three channel stack with one Base Module, The top and bottom printed circuit boards of the Module 6004 contain the necessary connectors to support stacking multiple modules. An additional Base Add-on module 6004 with its own node address expands the stack to another set of thirty three channels without the need of additional IntelliBus connectors.

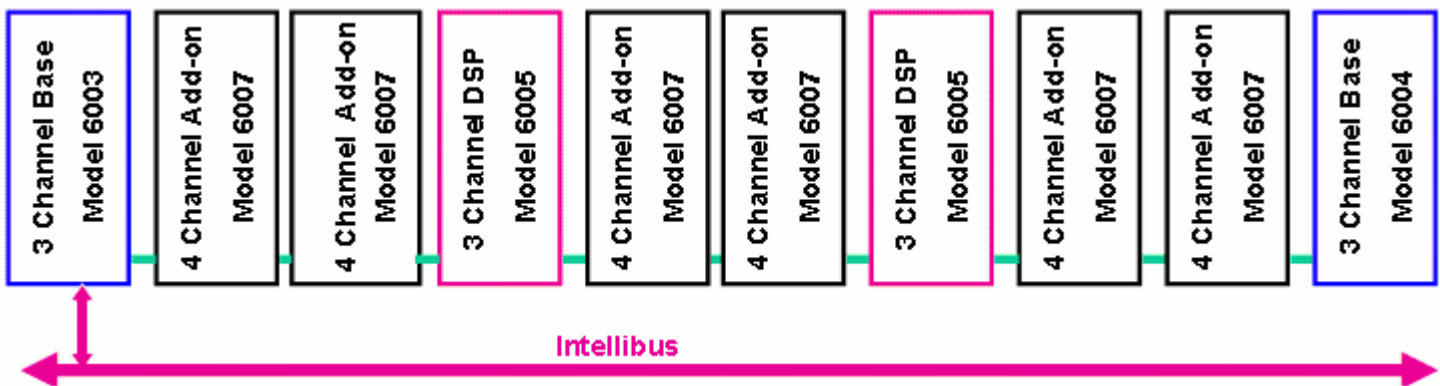

IBIM Stack: The Three Channel Base Module Allows Stacking up to 33 Channels With a Single IntelliBus Network Drop Address

Three Channel Base Add-on Module

MODEL 6004

SPECIFICATIONS

The following performance specifications are at +75°F (+24°C) and 100 Hz, unless otherwise noted.

Electrical Inputs Characteristics

Differential Input

Input Impedance	10 MΩ Minimum for gain ≥4	27KΩ Max for gain ≤4
Voltage Input	0 to 3.5V Max for gain ≥4	0 to 16 V Max for gain ≤4
Common Mode Rejection	60dB	

Electrical Transfer Characteristics

Gain	Programmable 0.5 to 1000
Accuracy	0.2%
Linearity	0.005%

Frequency Response

Bandwidth Without Filter	DC to ≥ 30K Hz
Anti-aliasing Low Pass Filter	3 pole Butterworth
-3dB Upper Freq. Corner	2,000 Hz or 360 Hz Software selectable and factory customized
Programmable Filter	64th Order FIR type – TEDS programmable coefficients
Programmable Cutoff Freq	Proportional to sample rate, decimation factor and filter's coefficients – See application Notes
Residual Noise	< 2mV RMS RTO

Analog/Digital Conversion

Sample Rate	250 Ksps maximum or 300 Ksps aggregate for all 3 channels
Resolution	16-Bits

Electrical Output Characteristics

Excitation Voltage Output	5Vdc 40 mA Maximum
Transducer Bus	½ Duplex IntelliBus compatible
Data Rate	15Mbps. See sample rate Vs Number of IBIMs plot

POWER

Supply Voltage	12 to 28 VDC	2.4 Watts Maximum
Warm-Up Time	3 seconds to within 10% of final basis	
Case Isolation	Output and signal ground, 100 MΩ minimum @ 100 Vdc	

ENVIRONMENTAL CONDITIONS (MIL-STD-810)

Temperature	Operating -40°F TO 185°F (-40°C TO +85°C) Non-operating -76°F TO 302°F (-60°C TO +150°C)
Vibration	Sine 30g, 10 Hz to 2,000 Hz Random 30g, 10z to 2,00 Hz
Shock	50g, half sine
Humidity	to 95% RH non-condensing
EMI	Per MIL-STD-461, 462

PHYSICAL

Weight	1.6 Oz.
Case Material	Anodized Aluminum
Cable Type	Double shielded 2 pairs, 24AWG: Tensolite NF24Q100-01
IntelliBus Connector	Lemo: FGG-OB-304-CLAD42 and FGG-OB-304-CLLD42

Three Channel Base Add-on Module

Digital Filter:

MODEL 6004

Different analysis and control functions may be implemented using DSP algorithms that can be downloaded to an IBIM through the transducer bus. A 64 order FIR filter is provided as a standard function. Its coefficients may be customized and downloaded through the IntelliBus network as part of the system setup and stored in TEDS memory. The low pass filter cutoff frequency (F_c) is determined by the A/D sample frequency and a preset constant

$$F_c = F_{ad}/R$$

Where $R = 4, 8, 12, 16, 24, 32$

The Sample rate frequency over the transducer bus (F_s) is determined by the A/D sample frequency and the decimation factor D

$$F_s = F_{ad}/D$$

Where $D \leq R/2$ Integer

One of the two anti-aliasing filters is selected depending on the over sample frequency according to the Nyquist criteria. The recommended over sample frequency should be between 100 kHz and 16 kHz when the 2 kHz anti-aliasing filter is used, or between 11,520 Hz and 2,880 Hz when the 360 Hz anti-aliasing filter is used.

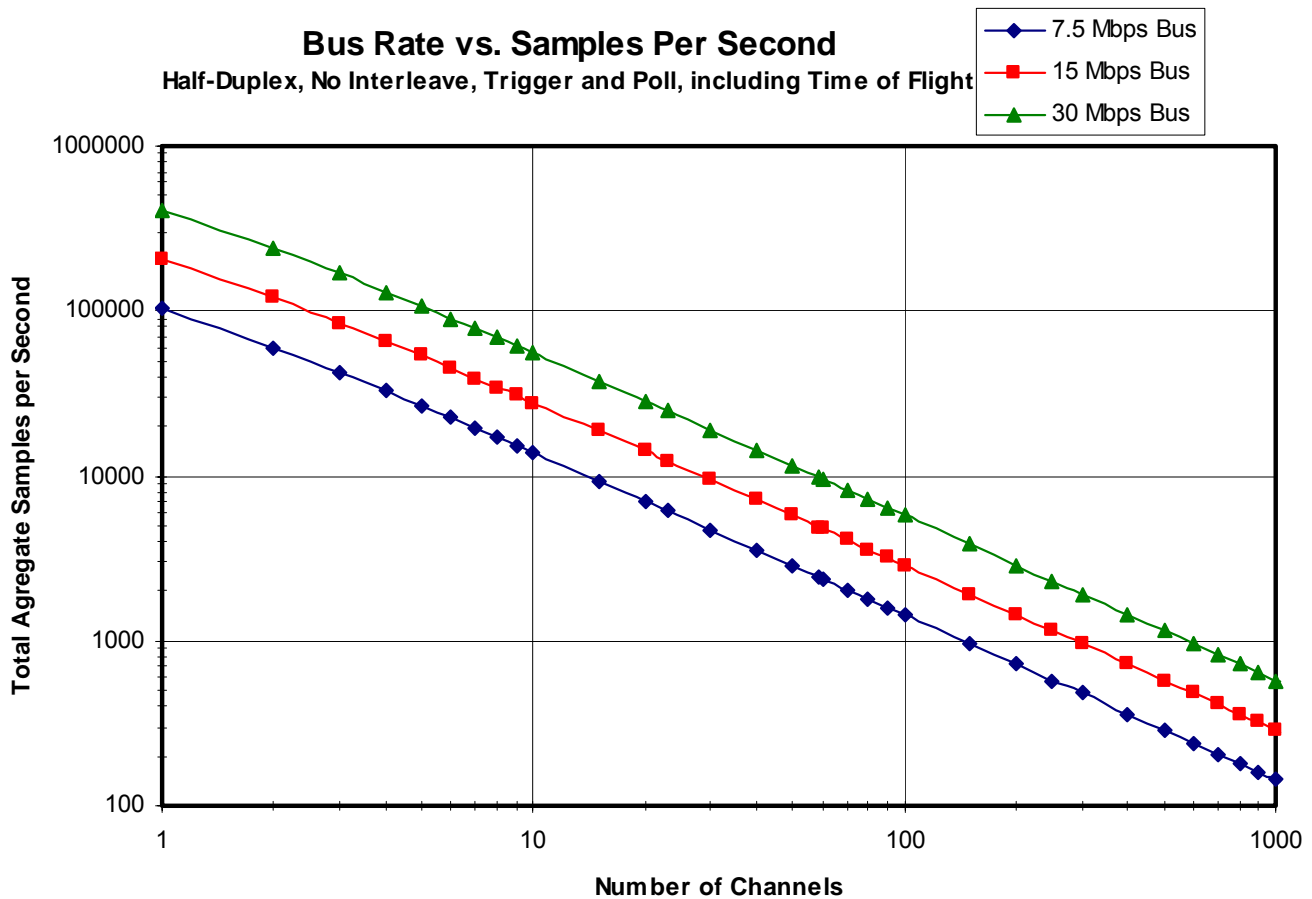

Figure 4: Bus Transfer Rate – Sample Rate Versus Number of IBIMs